



**Spray Polyurethane Foam
Aggregate Systems
for
New and Remedial
Roofing**

**RECOMMENDED
DESIGN CONSIDERATIONS
AND GUIDE SPECIFICATIONS**

**Spray Polyurethane Foam Alliance
4400 Fair Lakes Court, Suite 105
Fairfax, VA 22033**

Copyright 1990

Technical Committee

Chairman:
Roger Morrison
North Carolina Foam Industries

Mary Bogdan
Honeywell

Bob Braun
Dow Chemical

John Courier
Equipment & Coatings Technology

John Ewell
Dallas/Ft. Worth Urethane, Inc.

John Hatfield
Penta Engineering Group, Inc

Tim Leonard
ERSystems

Roger Lock
Mactec Engineering & Consulting

Jack Moore
West Roofing Systems, Inc.

Bruce Schenke
BASF

Mort Sherman
consultMORT, Inc.

Larry Smiley
Poly-Tek

Robert Smith
Invista

John Stahl
Preferred Solutions, Inc.

AD HOC MEMBERS:

Laverne Dalglish
CUFCA

This brochure was developed to aid specifiers in choosing spray-applied polyurethane foam systems. The information provided herein, based on current customs and practices of the trade, is offered in good faith and believed to be true, but is made WITHOUT WARRANTY, EITHER EXPRESS OR IMPLIED, AS TO FITNESS, MERCHANTABILITY, OR ANY OTHER MATTER. SPFA DISCLAIMS ALL LIABILITY FOR ANY LOSS OR DAMAGE ARISING OUT OF ITS USE. Individual manufacturers and contractors should be consulted for specific information. Nominal values which may be provided herein are believed to be representative, but are not to be used as specifications nor assumed to be identical to finished products. SPFA does not endorse the proprietary products or processes of any individual manufacturer or the services of any individual contractor.

Table of Contents

DESIGN CONSIDERATIONS

General Considerations	4
Surface/Deck Preparation—Procedures and Considerations	4
Selection of Primer	5
Selection of the Polyurethane Foam System	5
Selection of the Aggregate Cover.....	5
Selection of a Protective Coating	6
Maintenance Procedures.....	6

PART 1- GENERAL

1.01	Scope of Work	6
1.02	Related Work Specified Elsewhere	6
1.03	Quality Assurance	7
1.04	Submittals	7
1.05	Materials, Delivery and Storage	8
1.06	Environmental Conditions	7
1.07	Sequencing and Scheduling	8
1.08	Warranty	8
1.09	Safety Requirements	8

PART 2 - PRODUCTS

2.01	Polyurethane Foam	8
2.02	Asphaltic Coatings	8
2.03	Elastomeric Coatings	9
2.04	Aggregate	9
2.05	Accessories and Miscellaneous Materials	9

PART 3 - EXECUTION

3.01	Surface Preparation	10
3.02	Polyurethane Foam Application	11
3.03	Protective Covering Application	12
3.04	Safety Requirements	13

SPF TEXTURE PHOTOS

Photo a.	Polyurethane Foam Texture - Smooth	13
Photo b.	Polyurethane Foam Texture - Orange Peel	13
Photo c.	Polyurethane Foam Texture - Coarse Orange Peel	13
Photo d.	Polyurethane Foam Texture - Rippling-Verge of Popcorn	13
Photo e.	Polyurethane Foam Texture – Popcorn and/or Treebark	13

ILLUSTRATIONS

Detail 1	Typical Roof Drain	14
Detail 2	New & Remedial Roof Edge	15
Detail 3	Self Flashing at Parapet Wall	16
Detail 4	Typical Vent Pipe	17

DESIGN CONSIDERATIONS

GENERAL CONSIDERATIONS

The performance of a Spray Polyurethane Foam (SPF) roofing system can be affected by all the component parts of a roof structure, as well as the atmospheric conditions inside and outside the structure. Aggregate covered SPF roofs should not be considered for roofing non-vented refrigeration or freezer buildings.

Proper structural design, specification review, contractor and material selection, conformance to building code(s), coupled with the compatibility and positioning of the various components of a roof structure, are necessary to produce a successful roofing system.

Consult with the respective material suppliers and the contractor to receive written confirmation of their agreement/opinion to all facets of the roofing system, including, but not limited to, material selection, proper drainage, expansion joints, load design, flashing details, deck preparation, warranty, etc.

SURFACE/DECK PREPARATION--PROCEDURES AND CONSIDERATIONS

There are numerous types of substrates to which SPF can be applied. Each must be assessed individually. However, the following general practices must be observed on all decks which are to receive SPF.

1. General Surface/Deck Preparation Procedures

- A. The roof deck shall be securely fastened to the building structure and conform to proper load limits of good engineering practices. Special attention should be focused on the deflection under all type roof conditions, including, but not limited to, foot traffic, mechanical equipment utilization, as well as live and dead loads.
- B. When a primer and/or a vapor retarder are specified, there must be adequate adhesion between all components of the system to secure the entire system against wind uplift and movement.
- C. Prior to application of primer, vapor retarder or SPF, the deck shall be properly cured, dry, and free of loose dirt or any contaminants that may interfere with proper adhesion of any of these components.
- D. Deck contaminants are removed, depending on their severity and quantity, by use of air pressure, vacuum equipment, hand power broom, abrasive blasting, manual scraping, etc.
- E. The aggregate covered SPF roofing system is suitable for roofs up to 40 mm/m (one-half [1/2] inch per foot) slope. It is the responsibility of the specifier to evaluate the load bearing capacity of the roof deck to insure safe weight limits are not exceeded.

2. Wood Surfaces/Decks

- A. A pre-treatment with a primer is necessary to achieve maximum adhesion of the SPF to a wood deck.
- B. Joints in excess of 6 mm (1/4" in) width shall be sealed prior to the application of the respective primer, vapor retarder or SPF.

3. Metal Surfaces/Decks

- A. A slope of 10 mm/m (1/8" in 12") or more is recommended, but should not exceed 40 mm/m (1/2" in 12").
- B. The metal deck should not be lighter than 22 gauge.

- C. Underlayment, if specified for smoother application of SPF, should be of sufficient width and thickness to span or fill flutes. Fastening shall be in accordance to applicable code requirements. See Section 3.02, B, 5.

4. Concrete Surfaces/Decks

- A. In all cases, concrete should be free of laitance and chemical release agents.
- B. Generally, priming is required on concrete surfaces, and it is recommended that due to the water of hydration that is present, poured concrete decks be permitted to cure for twenty-eight (28) days prior to the application of sprayed polyurethane foam.
- C. All joints should be filled and/or taped.
- D. SPF is not recommended for lightweight or insulating concretes unless an overlayment is installed.

SELECTION OF PRIMER

Consult SPF manufacturer for proper primer selection according to the surface to be sprayed.

SELECTION OF THE POLYURETHANE FOAM SYSTEM

A wide range of SPF systems are available in various densities, each exhibiting different temperature limitations, combustibility characteristics, etc. The use of these systems, in combination with each other or with other conventional insulation products, offers a wide range of economical installations.

As a purchaser, you should understand that most published data is based on laboratory produced samples. The thickness of SPF sprayed, number of passes, temperature of substrate, ambient temperatures, etc. have a pronounced effect on all properties.

From a fire safety standpoint, SPFs can be used safely. It is important, however, that all persons associated with the design, fabrication, storage and installations understand the materials and environments involved.

SPF insulation is combustible and should be treated as such. Flame spread ratings provided for polyurethane products using small scale tests are not intended to reflect the hazards presented by this or any other materials under actual fire conditions. Care must be taken to ensure that the SPF is not exposed to heat or flame.

SELECTION OF THE AGGREGATE COVER

When SPF is applied externally, as an integral part of the roofing system, it must be given a protective covering for ultra-violet light protection. Aggregate (gravel or slag) may be used to afford this protection.

The selection of gravel or slag is usually determined by local availability; the size of the gravel/slag being more important than the type. A mixture of gravel/slag sizes should be used, with the larger pieces approaching 20 mm (3/4 inch). Flat surfaced gravel/slag is preferable to round.

Aggregate may be subject to scour due to wind or water flow. Each roof should be examined for scour potential. Scour may be minimized or eliminated by adhering the aggregate at critical areas of the roof using elastomeric coatings. Parapets will also reduce scour potential.

A secondary UV barrier “coating” may be applied prior to aggregate application. This must have a perm rating of 300 ng/s·m²·Pa (5.0 US perms) or more based on ASTM E 96 Procedure B.

SELECTION OF A PROTECTIVE COATING

Vertical surfaces, surfaces exceeding 40 mm/m (1/2" in 12") and other SPF surfaces where gravel/slag may not be stable are usually protected through the application of an elastomeric coating.

The vertical surface coating shall be a system which will cure to form a water resistant protective membrane. The dry film thickness (DFT) of the protective coating shall be in compliance with the SPF manufacturer's specification. The properties of the cured protective coating shall meet the minimum design characteristics of the generic type specified. The protective coating shall be specifically manufactured for the weather protection of SPF as used in roofing applications.

MAINTENANCE PROCEDURES

It is recommended that maintenance procedures, including annual inspections, be established with your selected contractor for any roofing system to yield its full value.

CONTACT THE RESPECTIVE MANUFACTURERS/ SUPPLIERS AND CONTRACTORS FOR RECOMMENDED MAINTENANCE PROCEDURES.

RECOMMENDED GUIDE SPECIFICATION FOR NEW AND REMEDIAL ROOFING

NOTE: This guide is designed to help the specifier achieve a successful aggregate covered Spray Polyurethane Foam (SPF) roofing system. It is the responsibility of the specifier to consult with the chosen manufacturer of material specified as to the manufacturer's specific recommendations.

PART 1—GENERAL

This guide discusses the application of a seamless Spray Polyurethane Foam (SPF) roofing system with an aggregate covering. Your contractor, selected systems manufacturer and local code agencies can assist you, as each project must be assessed individually.

1.01 SCOPE OF WORK

Furnish all labor, materials, and equipment necessary for the application of an aggregate covered SPF roofing system, including accessory items, subject to the general provisions of the contract.

1.02 RELATED WORK SPECIFIED ELSEWHERE

A. Cast-In-Place Concrete	Section 033000
B. Metal Decking	Section 053000
C. Rough Carpentry	Section 061000
D. Thermal Protection	Section 072000
E. Membrane Roofing	Section 07500
F. Flashing and Sheet Metal	Section 07600
G. Roof Specialties and Accessories	Section 07700
H. Roof Windows and Skylights	Section 086000
I. Mechanical	Division 15
J. Electrical	Division 16

1.03 QUALITY ASSURANCE

- A. Contractor Qualifications: The proposed contractor should provide information concerning projects similar in nature to the one proposed including location and person to be contacted. Some manufacturers of SPF systems and/or weather protective coatings have approval programs and/or licensing methods that could be required.
- B. Manufacturer Qualifications: SPF and protective coating manufacturers shall show evidence of sufficient financial resources and manufacturing facilities to furnish materials on this project. References shall be required, sufficient project lists, warranties and code approvals shall be submitted for verification.
- C. Inspections: The SPF and protective coating manufacturers are to provide qualified representatives to monitor and inspect the installation of their products. Third party inspection of the installation is recommended. A list of SPFA inspector members is available.

1.04 SUBMITTALS

- A. Manufacturers to provide published data sheets or letter of certification that their products comply with the materials specified. This is to include primers (if required), SPF and protective coatings.
- B. Shop drawings on sheet metal, accessories, or other fabricated items.
- C. Manufacturer's application or installation instructions.
- D. Contractor/applicator certification from SPF supplier and/or protective coatings manufacturers as evidence of contractor/applicator qualification and experience. See Section 1.03A
- E. A specimen copy of the applicable warranty for the project. See Section 1.03B
- F. Approval and information guides for applicable local or national codes and/or insurance acceptability, and UL certificates if required.
- G. Safety and handling instructions for storage, handling and use of the materials to include appropriate Materials Safety Data Sheets (MSDS).
- H. Field Quality Control Procedures are to be utilized by the contractor/applicator to ensure proper preparation and installation of SPF and protective coating, detail work and follow-up inspection.
- I. SPFA spray polyurethane foam surface visual guide.

1.05 MATERIALS, DELIVERY AND STORAGE

- A. Materials shall be delivered in the manufacturers original, tightly sealed containers or unopened packages, all clearly labeled with the manufacturer's name, product identification, safety information, approvals and batch or lot numbers where appropriate. Where materials are covered by a referenced specification, the labels shall bear the specification number, type and class, as applicable.
- B. Containers shall be stored out of the weather and direct sunlight where the temperatures are within the limits specified by the manufacturer.
- C. All materials shall be stored in compliance with local fire and safety requirements.

1.06 ENVIRONMENTAL CONDITIONS

- A. The SPF and protective coatings applications shall not proceed during periods of inclement weather or when there is ice, frost, moisture or visible dampness present on the surface. Apply the SPF and protective coatings within the temperature and humidity limits established by the manufacturers. Apply SPF and protective coatings in accordance with the

manufacturers' application instructions.

- B. Wind barriers may be used if wind conditions could affect the quality of the SPF or protective coating installation.

1.07 SEQUENCING AND SCHEDULING

In new construction projects the SPF is installed when the deck, parapet walls, rough openings, and curbs are completed. The type of skylight used will determine when skylights should be installed. Plumbing vents, drains, and electrical penetrations should all be in place. There should not be any other trades-persons working on the roof when the SPF and coverings are being installed.

1.08 WARRANTY

Warranty agreements vary in duration and content. A warranty is recommended, and it is suggested that parameters be established as a prerequisite to the execution of a contract.

1.09 SAFETY REQUIREMENTS

See SPI Bulletin AX-119, “MDI-Based Polyurethane Foam Systems: Guidelines for the Safe Handling and Disposal.”

PART 2—PRODUCTS

2.01 POLYURETHANE FOAM

- A. The SPF to be applied shall be a two component system made by combining an isocyanate (A) component with a polyol (B) component and shall possess the following physical characteristics:

PROPERTIES	ASTM TEST	VALUE (SI)	UNITS (SI)	VALUE (US)	UNITS (US)
Density (sprayed in place)	D-1622	45 – 48	kg/m ³	2.8 – 3.0	lb/ft ³
Compressive Strength	D-1621	275 min	kPa	40 min	lb/ft ²
Closed Cell Content	D-2856	90% min		90% min	
R-Value per 25 mm (per inch)	C-177 or C-518	0.98 min	$\frac{K \cdot m^2}{W}$	5.6 min	$\frac{^{\circ}F \cdot hr \cdot ft^2}{Btu}$
Flame Spread*	E-84	Not more than 75 FSI (flame spread index)			

* This standard is used solely to measure and describe properties of products in response to heat and flame under controlled laboratory conditions. This numerical flame spread rating is not intended to reflect hazards presented by this or any other material under actual fire conditions.

- B. SPF Primers: Primers used shall be as recommended by the manufacturer of the SPF materials specified.
- C. Fire Safety Requirements: See API Bulletin AX-230. “Fire Safety Guidelines for Use of Rigid Polyurethane and Polyisocyanurate Foam Insulation in Building Construction.”

2.02 SECONDARY UV BARRIER COATING

The perm rating as applied shall be greater than 300 ng/s•m²•Pa (5.0 US perms) and recommended by the SPF manufacturer.

2.03 ELASTOMERIC COATINGS

- A. The elastomeric coating may be one or more of the following types:
1. Acrylics
 2. Butyls
 3. Silicones
 4. Polyurethane elastomers

(NOTE: Specifier shall choose system in accordance to requirements of manufacturer issuing warranty.)

- B. Physical Properties: The elastomeric coating shall possess the following physical characteristics (NOTE: Specifier shall list physical properties of chosen elastomeric coating system):

PROPERTY	ASTM TEST	VALUE
Tensile Strength	D-412	_____
Elongation	D-412	_____
Hardness Shore "A"	D-2240	_____
Tear Resistance (lb per lineal inch)	D-624	_____
Ultra Violet Exposure	G-151 or G-153	_____
Moisture Vapor Transmission	E-96 Procedure E	_____
Fire Resistance of System*	E-108	_____

*This standard is used solely to measure and describe properties of products in response to heat and flame under controlled laboratory conditions. This classification is not intended to reflect hazards presented by this or any other material under actual fire conditions.

See AY-102, "A Guide for Selection of Protective Coatings over Spray Polyurethane Foam Roofing Systems," for additional information on specifying elastomeric coatings.

2.04 AGGREGATE

Aggregate (gravel or slag) will meet ASTM D-1863 Size No. 7 (12.5 mm to 4.75 mm [1/2 inch to sieve size 4]) or Size No. 67 (19.0 mm to 4.75 mm [3/4 inch to sieve size 4]).

2.05 ACCESSORIES AND MISCELLANEOUS MATERIALS

- A. Flashings and waterproof coverings for expansion joints shall be compatible with specified SPF and elastomeric coating and shall be as recommended by the manufacturers of the systems used.
- B. Miscellaneous materials, such as adhesives, elastomeric caulking compounds, metal, vents and drains shall be a composite part of the roof system and shall be those recommended by the systems manufacturer.
- C. Boardstock: If required over roof decks, fasten to achieve necessary wind uplift requirements.

PART 3—EXECUTION

3.01 SURFACE PREPARATION AND PRIMING

A. Built-up Roof (Retrofit)

1. All loose gravel, dust and residue shall be removed using power vacuum equipment, power broom, air blowing, or other suitable means.
2. The roof shall be thoroughly inspected or tested to determine if moisture is present within the roof assembly. Saturated insulation must be removed and replaced with compatible materials.
3. The existing roof shall be thoroughly inspected for adhesion between felts, insulation, and deck. Areas of poor adhesion should be fastened. Blisters, buckles, wrinkles and fishmouths shall be cut out and/or fastened.
4. All soft mastic or asphaltic materials that impede SPF adhesion must be removed.
5. Remove or refasten all loose base flashing, counterflashing and gravel stops as required.
6. The need may exist for structural design analysis by a certified engineer to determine if the roof structure is suitable for an aggregate covered SPF roofing system. Under no circumstances should this system be installed over a roof structure containing two or more existing built-up roofs. (Removal of the existing roofs is in these cases recommended.)
7. Lightning rods and cables should not be embedded in the SPF. Electrical and mechanical conduits should be relocated or raised above the finished roof surface.

B. Metal Deck

1. The metal roof deck shall be constructed of a minimum 22 gauge steel. Construction shall conform to local building codes.
2. Ferrous Metal: Remove loose rust and unsound primer from shop-primed iron and steel surfaces by scraping or wire brushing. Prime according to SPF manufacturer's recommendation.
3. Non-Ferrous Metal: Clean and prime galvanized metal, aluminum, and stainless steel surfaces as recommended by the manufacturer issuing the warranty.
4. If the metal surface is free of loose scale, rust, weathered or chalking paint, it can be cleaned using compressed air, vacuum equipment, hand or power broom to remove loose dirt. Grease, oil or other contaminants shall be removed with proper cleaning solutions.
5. Fluted metal decks require a suitable method of covering or filling the flutes prior to SPF application. Flutes may be covered/filled with mechanically fastened board stock, special polyester tapes, precut board stock or SPF.

C. Concrete

1. Remove loose dirt, dust and debris by using compressed air, vacuum equipment or brooming. Oil, grease, release agents or other contaminants shall be removed with proper cleaning solutions.
2. All joint openings in concrete decks that exceed 6 mm (1/4 inch) shall be grouted or caulked prior to application of SPF.
3. Lightweight or insulating concretes are not recommended for SPF application.

D. Wood

1. Plywood shall be exterior grade not less than 12 mm (15/32 inch) thick, fastened firmly in place. Attachment must meet building code requirements for resistance to wind uplift.
2. Plywood shall contain no more than 18% water, as measured in accordance with ASTM D-4444 or D-4442.
3. All untreated and unpainted surfaces shall be primed with exterior grade primer. Priming is required to minimize moisture absorption and eliminate potential problems with SPF adhesion.
4. Plywood joints in excess of 6 mm (1/4 inch) shall be taped or filled with a suitable sealant material.
5. Deck shall be free of loose dirt, grease, oil or other contaminants prior to priming or SPF application. Remove loose dirt or debris by use of compressed air, vacuum or brooming. No washing shall be permitted.
6. Tongue & Groove, Sheathing, Planking: Due to the frequency of joints, possibility of variable openings and effects of aging and shrinking these surfaces must be overlaid with minimum 6 mm (1/4 inch) thick exterior grade plywood or suitable covering.

E. Other Surfaces (i.e. Gypsum Board, Isocyanurate Board)

1. These materials are generally used over fluted metal decks and must be fastened to achieve necessary wind uplift resistance.
2. Boards shall be firmly butted together along all edges without gaps or openings. Joints exceeding 6 mm (1/4 inch) shall be filled with a suitable sealant material.
3. Special care must be taken to prevent these materials from getting wet in storage on the jobsite and after installation prior to being protected by SPF. Moisture exposure will damage these materials and may be a cause for replacement.
4. Remove loose dirt and debris by using compressed air, vacuum or light brooming. No power brooming is permitted due to possibility of damage.
5. The installed materials shall be protected from spills of contaminants such as oil, grease, solvents, etc., as these materials cause soiling that cannot be readily removed from the board surfaces.

3.02 POLYURETHANE FOAM APPLICATION

A. Inspection

1. Prior to application of the SPF, the surface shall be inspected to insure that conditions required by Section 3.01 have been met.
2. Ponding is defined as the accumulation of water in low-lying areas that exceeds the manufacturer's specifications and/or contract documents.
3. The SPF application shall not proceed during periods of inclement weather. The applicator shall not apply the SPF below the temperature and/or above the humidity specified by the manufacturer for ambient air and substrate. Wind barriers may be used if wind conditions could affect the quality of installation.

B. Application

1. The SPF shall be applied in accordance with the manufacturer's specification and instructions.
2. Areas to be built-up to remove ponding water are to be filled in with SPF before the specified thickness is applied to the entire roof surface. See Section 3.01A
3. The SPF must be applied in a minimal pass thickness of 12 mm (1/2 inch).
4. Total SPF thickness shall be a minimum of 40 mm (one and one-half inches) (or more if specified). The SPF shall be

applied uniformly over the entire surface with a tolerance of plus 6 mm (1/4") per 25 mm (inch) of thickness minus zero, except where variations are required to insure proper drainage or to complete a feathered edge.

5. The SPF shall be uniformly terminated a minimum of 100 mm (4 inches) above the roof line at all penetrations. Cants shall be smooth and uniform to allow positive drainage.
6. The full thickness of SPF in any area shall be applied prior to the end of each day.

C. Surface Finish

1. The final SPF surface shall be "coarse orange peel, or verge of popcorn."
2. Any damage or defects to the SPF surface shall be repaired prior to the protective coating application.
3. The SPF surface shall be free of moisture, frost, dust, debris, oils, tars, grease or other materials that will impair adhesion of the protective coverings.

3.03 PROTECTIVE COVERING APPLICATION

- A. Sidewalls, Parapets, Exposed Edges, etc.: Sloped surfaces exceeding 20 mm/m (1/2" in 12"), vertical surfaces and other surfaces which will not hold gravel, e.g. exposed roof edges, shall be coated with an elastomeric coating to achieve a minimum of 0.8 dry mm (30 dry mils) total or as specified. This coating should extend a minimum of 300 mm (12") onto the flat roof, from penetrations or verticals.

1. Base Coat

- a. The base coat shall be applied the same day as the SPF when possible. If more than 24 hours elapse prior to the application of base coat, SPF shall be inspected for UV degradation.
- b. The SPF shall be free of dust, dirt, contaminants and moisture before application of the base coat.
- c. The base coat shall be applied at a uniform rate of thickness to achieve the protective coating manufacturer's specified minimum dry film thickness. The amount of coating used will be influenced by the SPF surface texture.

2. Top Coat

- a. Application: Subsequent coating should be applied in a timely manner to insure proper adhesion between coats. Surface texture of SPF will affect dry film thickness—additional material may be required in areas of coarse SPF profile.
- b. Inspection: The cured dry film thickness of the finished multiple coat application shall be checked by taking slit samples and examining under magnification. Areas that are found to have less than the thickness specified shall require additional coating.

- B. Secondary UV Barrier Coating: (Optional) The perm rating as applied shall be greater than 300 ng/s•m²•Pa (5.0 US perms) and recommended by the SPF manufacturer.

C. Aggregate

1. Application: Gravel or slag shall be applied to achieve a minimum 20 mm (3/4 inch) thickness over all flat portions of the roof at a rate of 25 to 30 kg/m² (500 to 600 lbs. per square).
2. Gravel stored on the roof should be kept in small piles near the roof's periphery to minimize stresses to the roof deck. After most gravel has been applied it should be raked to insure uniform distribution and additional gravel added to areas thinner than 20 mm (3/4 inch).
3. Inspection: The entire flat roof surface will be visually inspected to verify the SPF is completely covered with at least 20 mm (3/4 inch) of aggregate. Areas found to have less than this thickness shall require additional aggregate.

3.04 SAFETY REQUIREMENTS

- A. See SPI Bulletin AX-119, “MDI-Based Polyurethane Foam Systems: Guidelines for the Safe Handling and disposal.”
- B. Refer to appropriate MSDS for other safety information.

Polyurethane foam surface textures

The surface texture of sprayed polyurethane foam influences the extra material needed to achieve the minimum in-place dry film thickness (DFT). Smoother surfaces require less coating material than rougher surfaces. It is also important to note that excessively rough surface textures must not be coated due to the inability of the coating material to provide complete coverage without voids, pinholes, etc. The photographs below show various polyurethane foam textures that have been established as industry reference standards. An elastomeric coating should **not be applied over a surface** texture rougher than verge of popcorn.

a. Smooth Surface Texture

Description: The surface exhibits spray undulation and is ideal for receiving a protective coating. Even though the surface texture is classified as smooth, this surface requires at least 5% additional material to the theoretical amount.



b. Orange Peel Surface Texture

Description: The surface exhibits a fine texture and is compared to the exterior skin of an orange. This surface is considered acceptable for receiving a protective coating. This surface requires at least 10% additional material to the theoretical amount.



c. Coarse Orange Peel Surface Texture

Description: The surface exhibits a texture where nodules and valleys are approximately the same size and shape. This surface is acceptable for receiving a protective coating because of the roundness of the nodules and valleys. This surface requires at least 25% additional material to the theoretical amount.



d. Verge of Popcorn Texture

Description: The verge of popcorn surface is the roughest texture suitable for receiving the protective coating. The surface shows a texture where nodules are larger than valleys, with the valleys relatively curved. The surface is considered undesirable due to the additional amount of coating required to protect the surface. This surface requires at least 50% additional material to the theoretical amount.



e. Popcorn Surface Texture or Tree bark

Description: The surface exhibits texture where valleys form sharp angles. This surface is unacceptable for coating application.



f. Oversprayed Surface Texture

Description: The surface exhibits a coarse textured pattern and/or a pebbled surface. This surface is typically found downwind from the spray polyurethane foam path and can vary from mild to severe. This surface requires 25% to 50% additional material to the theoretical amount. Severe oversprayed surfaces are not acceptable for coating applications.

DETAIL DRAWING 1.

TYPICAL ROOF DRAIN AGGREGATE COVERED

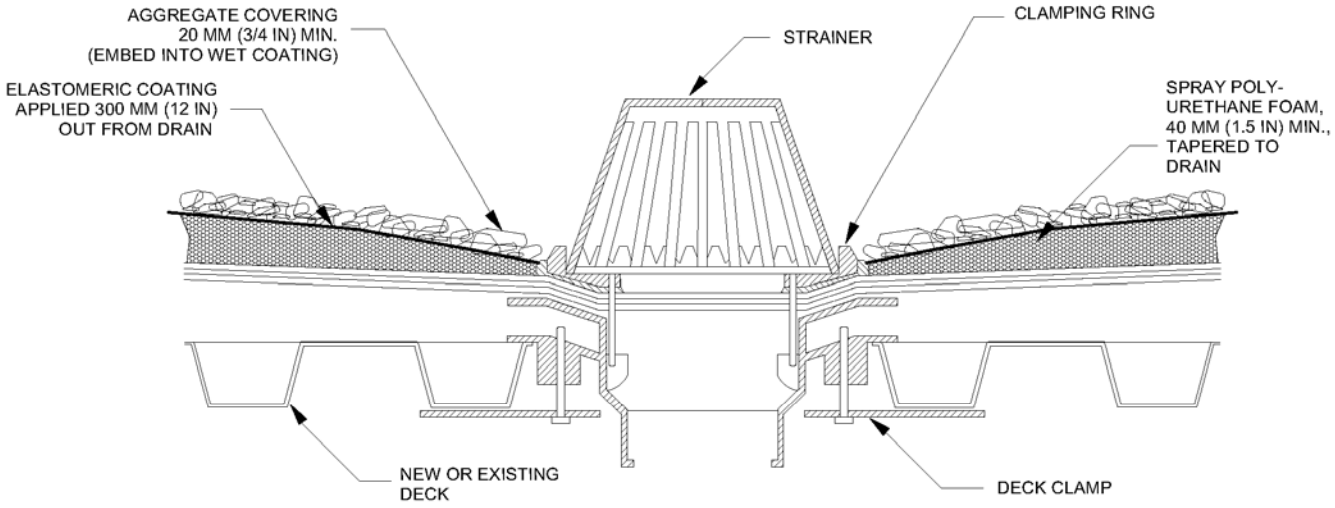

DETAIL DRAWING 2.

NEW & REMEDIAL ROOF EDGE AGGREGATE COVERED

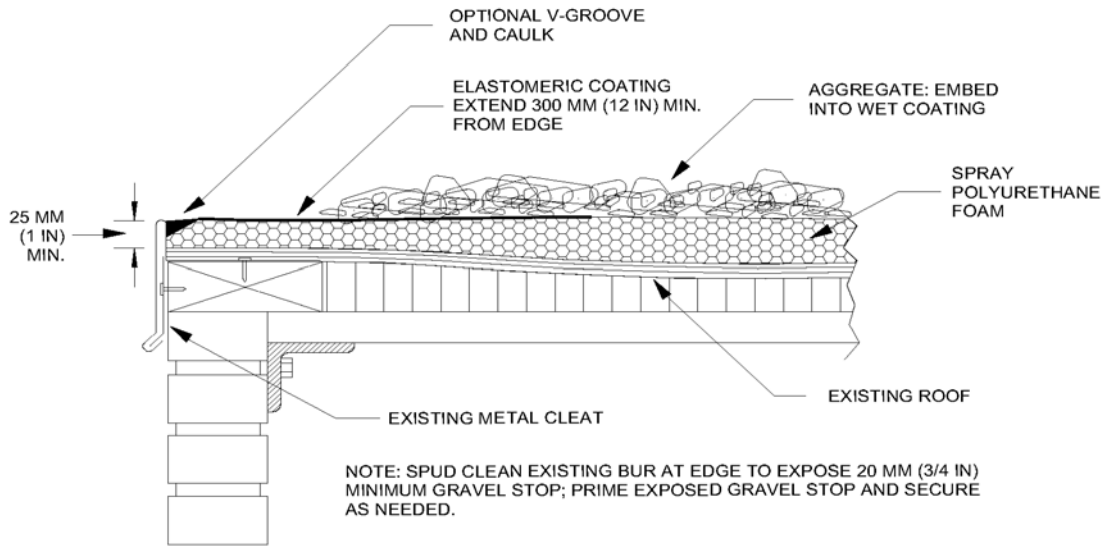

DETAIL DRAWING 3.

SELF FLASHING AT PARAPET WALL AGGREGATE COVERING

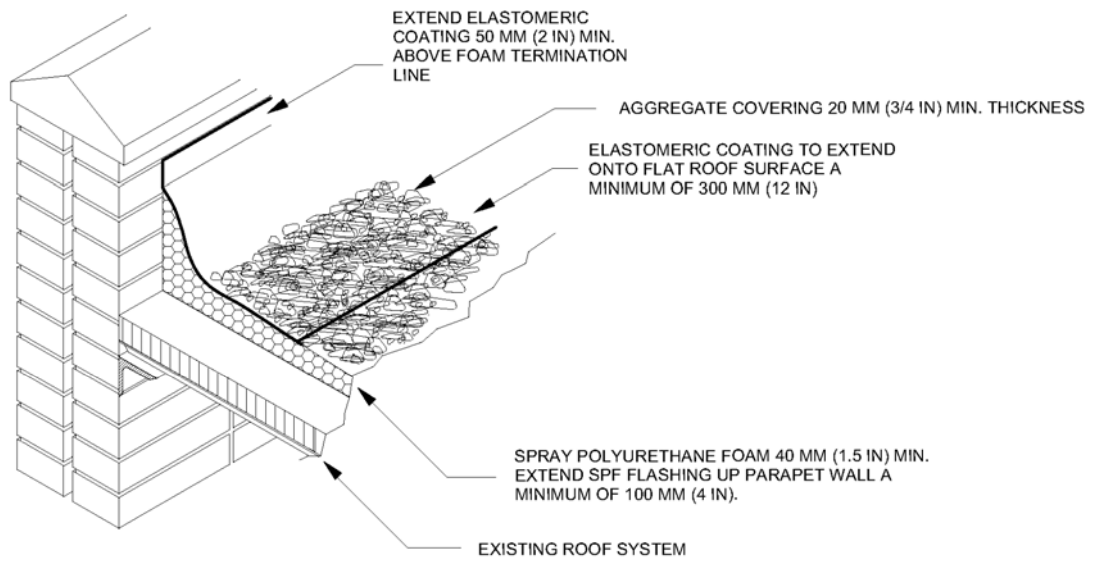

DETAIL DRAWING 4.

TYPICAL VENT PIPE AGGREGATE COVERED

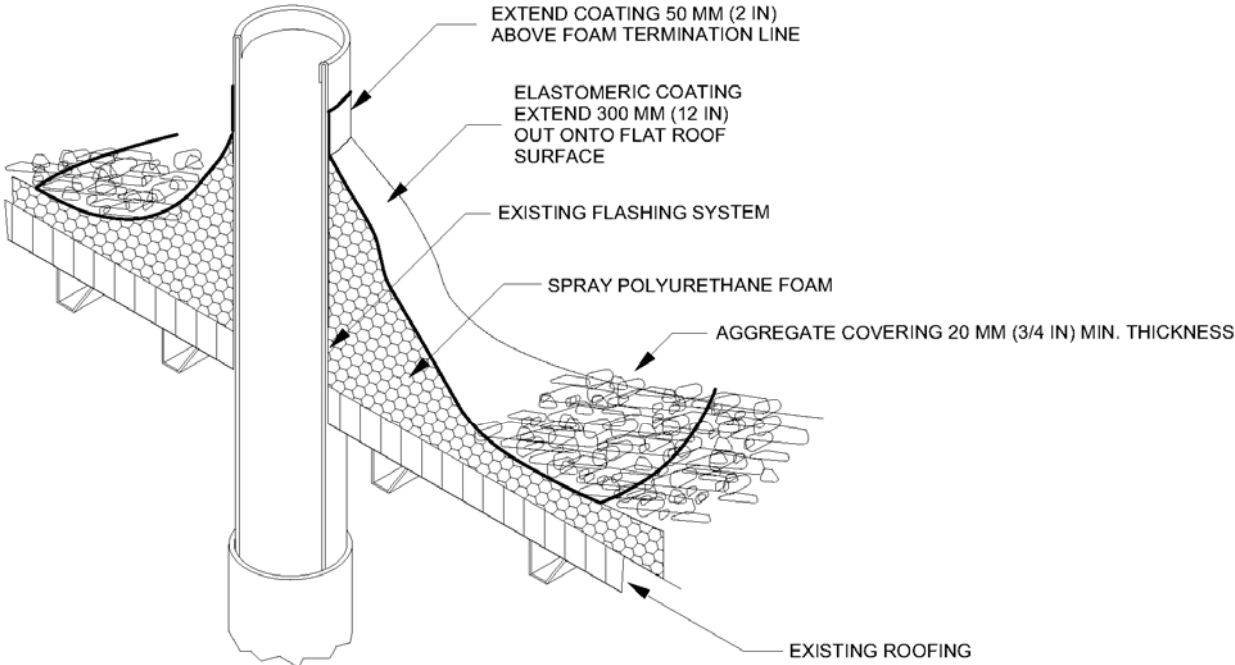

Technical Documents

- AY-102 A Guide for Selection of Protective Coatings Over Spray Polyurethane Foam Roofing Systems
- AY-103 Spray Polyurethane Foam Insulation Systems for Metal Service Vessels Operating Between -30°F and 200°F
- AY-104 Spray Polyurethane Foam Systems for New and Remedial Roofing
- AY-107 Spray Polyurethane Foam Blisters – Their Causes, Types, Prevention and Repair
- AY-110 Spray Polyurethane Foam Aggregate Systems for New and Remedial Roofing
- AY-111 Spray Polyurethane Foam Systems for Cold Storage Facilities Operating Between -40°F and 50°F
- AY-112 Spray Polyurethane Foam for Building Envelope Insulation and Air Seal
- AY-113 Contractor/Applicator Handbook
- AY-116 Spray Applied Polyurethane Foam and Elastomeric Coating Systems (10 min. VHS Video)
- AY-117 Spray Applied Polyurethane Foam and Aggregate Roof Systems (10 min. VHS Video)
- AY-118 Moisture Vapor Transmission
- AY-119 Glossary of Terms Common to the Spray Polyurethane Foam Industry
- AY-121 Spray Polyurethane Foam Estimating Reference Guide
- AY-122 The Renewal of Spray Polyurethane Foam and Coating Roof Systems
- AY-124 Wind Uplift Brochure
- AY-125 P-Rating Brochure
- AY-126 Thermal Barriers for Spray Polyurethane Foam Industry
- AY-127 Maintenance Manual for Spray Polyurethane Foam Roof Systems
- AY-129 SPF Roofing “Seamless Roofing & Insulation” 8 Page Color Brochure
- AY-130 SPF Roofing “Sustainable Roofing” 4 Page Color Brochure
- AY-131 Whole Wall Rating/Label for Metal Stud Wall Systems with SPF; Steady State Thermal Analysis
- AY-132 The SPF Roofing Systems – 11.5 min. Informative Video offers a comprehensive pictorial review of this most extraordinary roofing concept.
- AY-133 Maintenance Manual for Spray Polyurethane Foam Roof Systems – **Spanish Version**
- AY-134 Guideline for Insulating Metal Buildings with Spray Polyurethane Foam
- AY-135 Building Envelope Brochure
- AY-137 Spray Polyurethane Equipment Guidelines
- AY-138 Guideline for Roof Assembly Evaluation for Spray Polyurethane Foam Roof Systems
- AY-139 Recommendations for Repair of Spray Polyurethane Foam Roof Systems due to Hail and Wind Driven Damage.
- AY-141 Spray Polyurethane Foam and Cathedral Roofs and Cathedralized Attics.
- AX-171 Course 101-R Chapter 1: Health, Safety and Environmental Aspects of Spray Polyurethane Foam and Coverings. Video and Text

The SPFA Web Site is a direct communication to all member suppliers and contractors with web access. Up to date information is offered.... And as a member, you may link into the web site (www.sprayfoam.org)

A **“HOT-LINE” 800 number** is available for your use to answer those technical questions (**800-523-6154**). The SPFA sponsors research and development and product testing that allow approval for generic types of spray foams, coverings, and related products.